

A-A

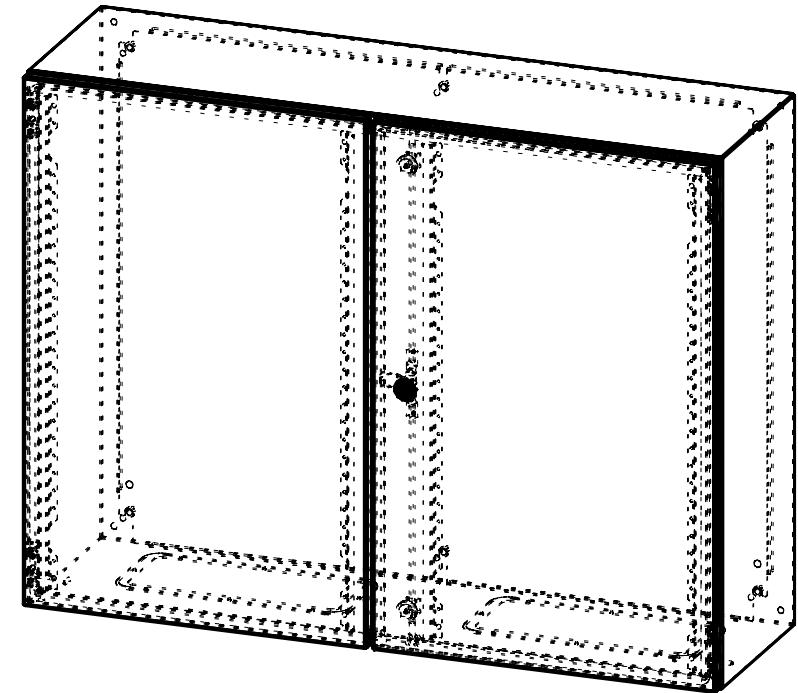
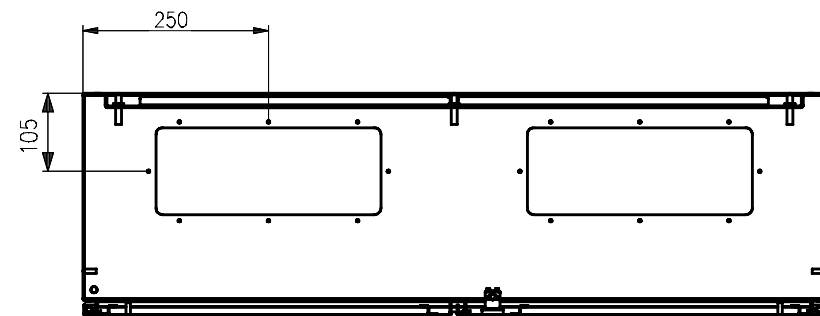

HTCAD

B Ausschnitt		10.06.2008 Peter						
Allgemeintoleranz ISO 2768 - mH								
Längenmasse - Toleranzklasse m (mittel)								
ueber	0.5	3	6	30	120	400	1000	Rundungshalbmesser
bis	3	6	30	120	400	1000	2000	Fasen, Winkel
	+0.1	+0.1	+0.2	+0.3	+0.5	+0.8	+1.2	Genauigkeitsgrad "m"
Mat :				Datum: 14.05.2008		System		RE
Obfl :				Bearb: Rohmann		Teil		Uniflex 4 1000x760x300
Tol :	s.o.	Blatt 1 von 1		Gepr:		Id-Nr		9RE_079
M :	1:10			C: 88358228. SZA				Index B

**caleg**  
gehäusesystem gmbh

Fuer diese Unterlage behalten wir uns alle Rechte vor.