

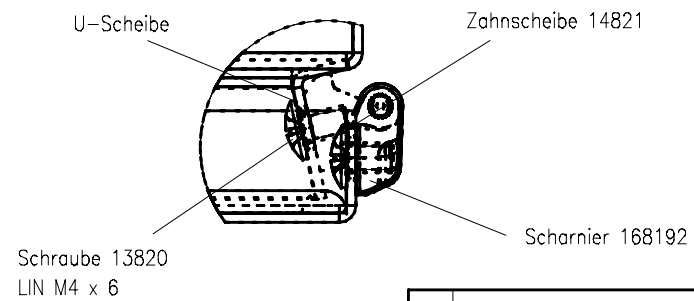

Z (1:1)



HFCAD

Allgemeintoleranz ISO 2768 - mH		Längenauswahl		Rundungshalbmesser		Fasen, Winkel		Genauigkeitsgrad "m"		 <p>Fuer diese Unterlage behalten wir uns alle Rechte vor.</p>		
Längenauswahl		Längenauswahl		Längenauswahl		Längenauswahl		Längenauswahl				
ueber	0,5	3	6	30	120	400	1000	2000	-		System	Pucel Thermodynamik
bis	3	6	30	120	400	1000	2000	4000	-			
	+0,1	+0,1	+0,2	+0,3	+0,5	+0,8	+1,2	+2,0	-		Blatt 1 von 1	Gepr:
Mat	: siehe Stkl.			Datum:			16.12.2008			Id-Nr		
Obfl	: siehe Stkl.			Bearb:			Rohmann				Index	A
Tol	: s.o.			Blatt 1 von 1			Gepr:					
M	: 1:2			C:			BA80C868. SZA					